



Instructions for Drilling and Assembling Flex Shaft™ and Dual Flex Shaft™ Handle Mechanisms for F-Frame Series C Circuit Breakers, Molded Case Switches, and HMCPs



WARNING

DO NOT ATTEMPT TO INSTALL OR PERFORM MAINTENANCE ON EQUIPMENT WHILE IT IS ENERGIZED. DEATH, SEVERE PERSONAL INJURY, OR SUBSTANTIAL PROPERTY DAMAGE CAN RESULT FROM CONTACT WITH ENERGIZED EQUIPMENT. ALWAYS VERIFY THAT NO VOLTAGE IS PRESENT BEFORE PROCEEDING WITH THE TASK, AND ALWAYS FOLLOW GENERALLY ACCEPTED SAFETY PROCEDURES.

CUTLER-HAMMER IS NOT LIABLE FOR THE MISAPPLICATION OR MISINSTALLATION OF ITS PRODUCTS.

The user is cautioned to observe all recommendations, warnings, and cautions relating to the safety of personnel and equipment as well as all general and local health and safety laws, codes, and procedures. The recommendations and information contained herein are based on Cutler-Hammer experience and judgment, but should not be considered to be all-inclusive or instructions for Drilling and Assembling Flex Shaft™ Handle Mechanism for K-Frame

Series C Circuit Breakers, Molded Case Switches, and HMCPs covering every application or circumstance which may arise. If any questions arise, contact Cutler-Hammer for further information or instructions.

GENERAL INFORMATION

The Flex Shaft handle mechanism provides a means of externally operating the circuit breaker and can be applied to enclosures of varying heights and depths. The handle can be used with NEMA 1, 3R, and 12 enclosure applications, depending on the accessory components selected. An operating handle, flexible shaft, and mechanism are required for standard application. Eight lengths of shafts are available for use with the wide range of depths of various enclosures (3' through 10'). When selecting the length of the Flexible Shaft, ensure Minimum Bending Radius of 4 inches is maintained to operate properly. The standard method of shipment includes the mechanism preset at the factory. If minor field adjustments are required see Figure 1-3 or Figure 1-9. For this publication, the term circuit breaker shall also include the molded case switch and Series C motor circuit protector (HMCP).

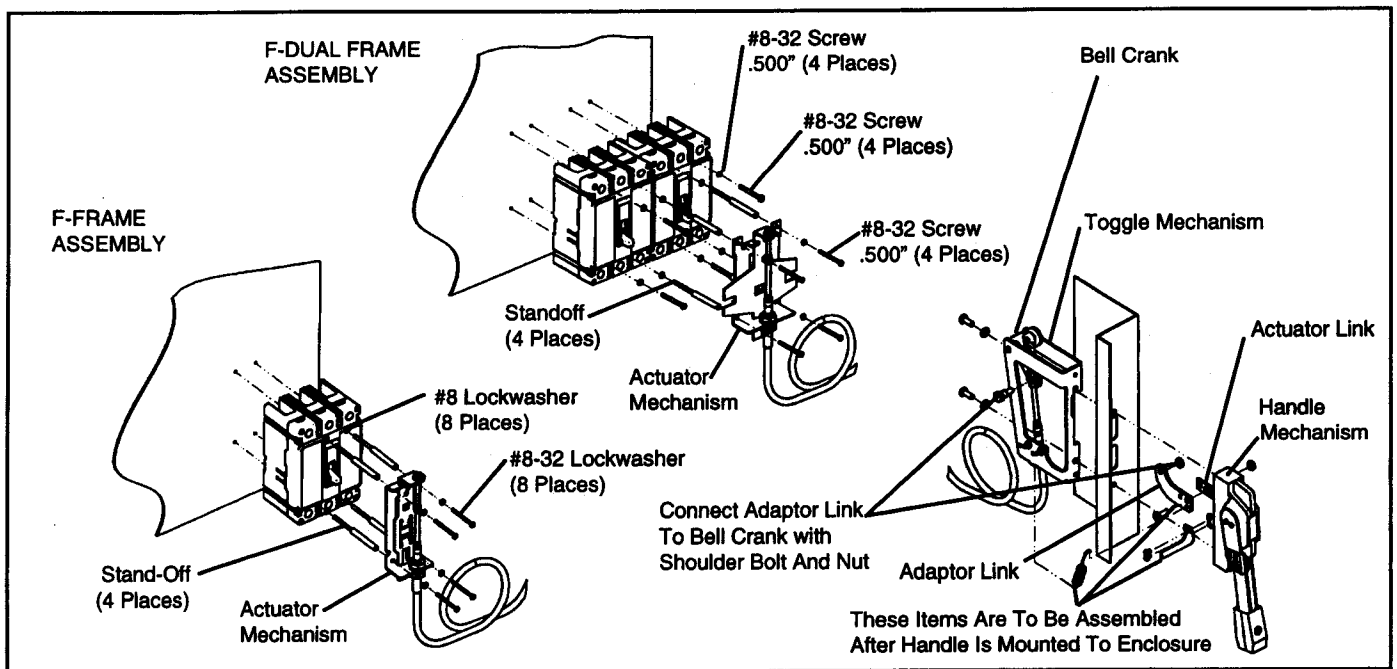

Fig. 1-1 Securing Actuator Mechanism to Breaker and Toggle Mechanism and Handle to Flange

**WARNING**

WHEN INSTALLING A NEW HANDLE MECHANISM, OR A NEW CIRCUIT BREAKER AND HANDLE MECHANISM IN AN EXISTING ELECTRICAL SYSTEM, MAKE SURE THERE IS NO VOLTAGE PRESENT WHERE WORK IS TO BE PERFORMED. SPECIAL ATTENTION SHOULD BE PAID TO REVERSE FEED APPLICATIONS TO ENSURE NO VOLTAGE IS PRESENT. THE VOLTAGE IN ENERGIZED EQUIPMENT CAN CAUSE DEATH OR SEVERE PERSONAL INJURY.

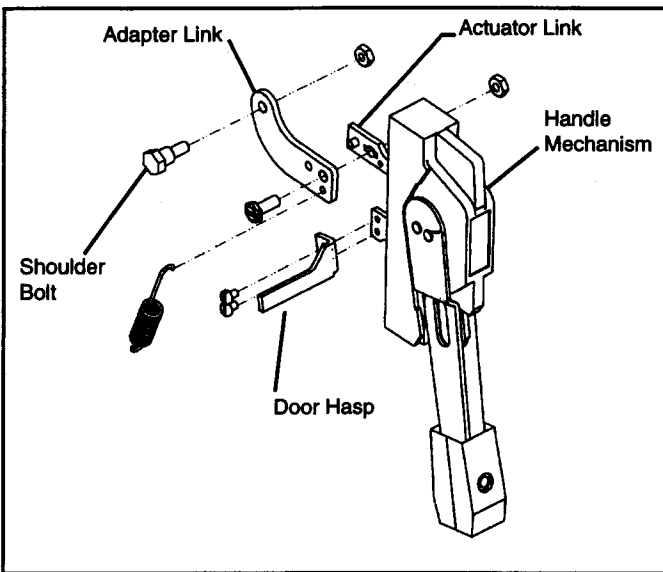

Fig. 1-2 Outer Handle Mechanism Assembly

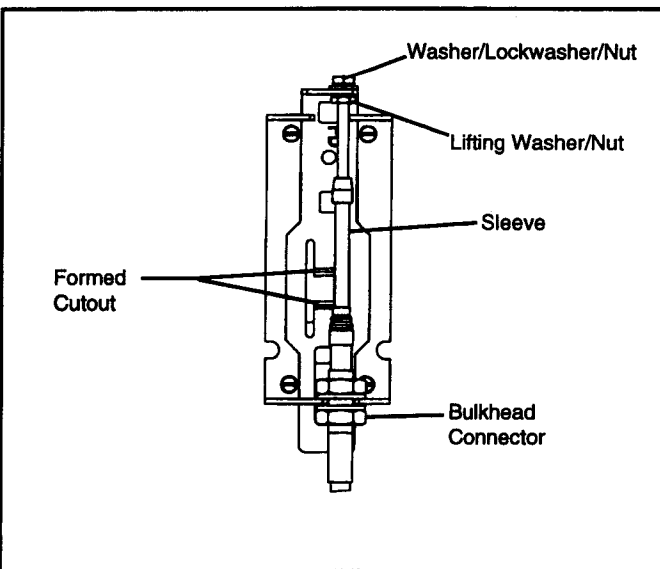

Fig. 1-3 F-Frame Dual Mechanism

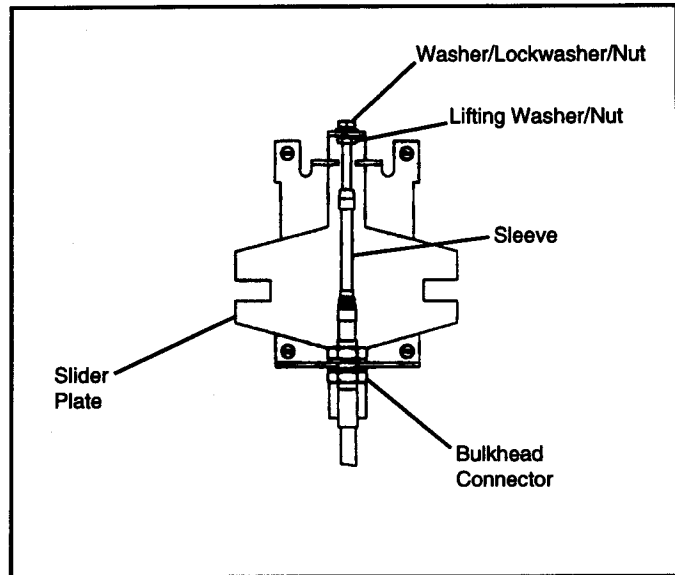

Fig. 1-4 F-Frame Dual Actuator Mechanism

F INSTALLATION

1. For the F-Frame Flex Shaft™ Handle Mechanism, install breaker with four standoffs and lockwashers. For the F-Frame Dual Flex Shaft™ Handle Mechanism, install each breaker with two standoffs & lockwashers (inner mounting holes of breaker) and two mounting screws & lockwashers (outer mounting holes of breaker). See Fig. 1-1.
2. Install handle to enclosure by removing the two screws and lockwashers from the outer handle mechanism. Place the outer handle mechanism with attached gasket over the enclosure cutout. Insert the top mounting screw with lockwasher through the enclosure and thread it into the outer handle mechanism for a few turns but not all the way.
3. Slide the toggle mechanism assembly over the top handle mounting screw. Insert the bottom handle mounting screw and lockwasher through the pivot bracket assembly, through the enclosure and into the handle. Fully tighten both mounting screws.
4. Connect the long end of the spring through the adapter link. See Fig. 1-5 for spring orientation. Then attach adapter link to the actuator link using the .250-20 hex head screw and nut. Rotate handle to ON position when attaching the spring.
5. Hook the shorter end of the spring into the tab on the lower portion of the toggle mechanism. See Fig. 1-6 for location.

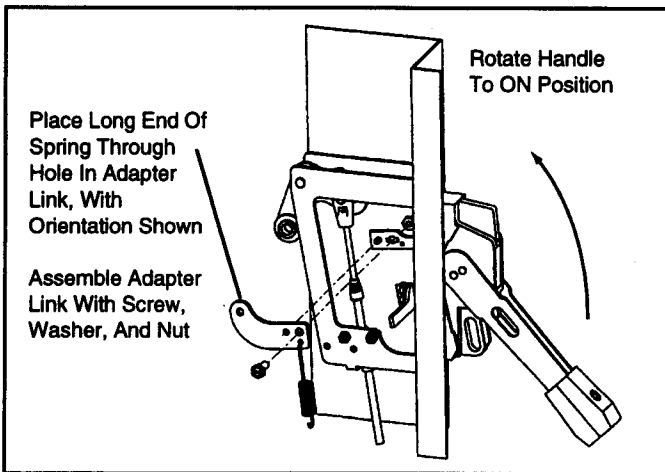

Fig. 1-5 Assembly of Spring and Adapter Link to Actuator Link

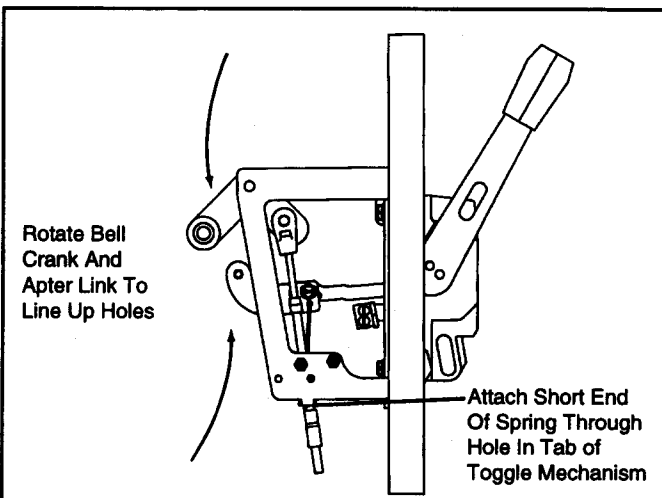

Fig. 1-6 Assembly of Spring to Toggle Mechanism

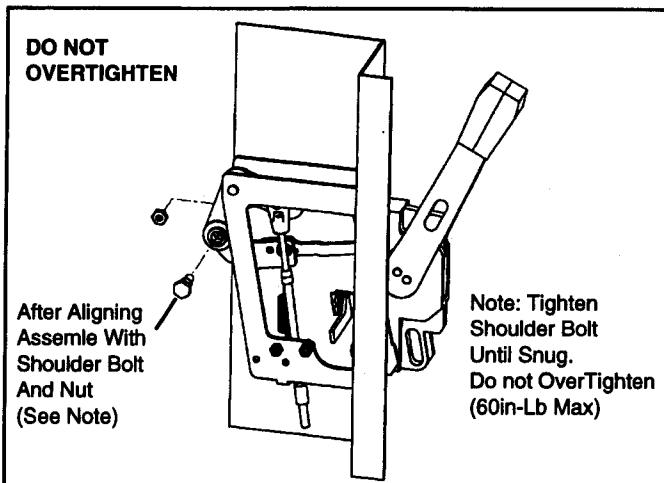

Fig. 1-7 Assembly of Adapter Link to Bell Crank Using Shoulder Bolt

NOTICE

Place handle in ON position before attempting to attach the spring.

6. Align adapter link with the bell crank. Attach bell crank to adapter link with shoulder bolt and nut. Fasten securely ... Do not overtighten. See Fig. 1-7.
7. Mount door hasp to handle using the two #8-32 SEMS screws.

NOTICE

See Fig. 1-2 for suggested orientation. Alternate orientations may be used according to application.

8. Put breaker and outer handle mechanism in the trip position for ease of mounting actuator mechanism.
9. Mount actuator mechanism to breaker. Insert the four #8-32x.5 screws and lockwashers through the mechanism and into the fasteners. Fasten securely ... Do Not Overtighten.
10. Operate handle mechanism to ensure functionality. To operate either close door or defeat door interlock lever.
11. If minor adjustments are necessary, refer to adjustment checklist.
12. Install appropriate door hardware (supplied).



WARNING

BEFORE ANY INSTALLATION OR MAINTENANCE IS PERFORMED, MAKE SURE THAT THE BREAKER IS NOT ENERGIZED.

ALTERNATE INSTALLATION

In the event a customer must disassemble the preassembled Flex Shaft handle mechanism, the following procedure must be followed before continuing with the installation instructions. (See Fig. 1-4).

1. Remove the flat washer, lockwasher, and nut assembly.
2. Loosen bulkhead connectors and remove Flex Shaft from actuator mechanism. Shaft may not be routed as required.

3. Place circuit breaker in the ON position.
4. Place the operating handle in the full ON position.
5. Replace Flex Shaft through the actuator mechanism. Center the bulkhead connectors on the threaded portion and tighten to approximately 70 lb.-in.
6. Place formed cutout in the slider plate over the breaker handle while still in the ON position. Turn the lifting washer/nut until flush against the slider plate.
7. Replace the flat washer, lockwasher, and nut assembly for the Flexible shaft assembly. Tighten both nuts to approximately 45 lb.-in.
8. Check operation of mechanism for ON, OFF, and reset. Check the reset position of the actuator mechanism, that the lifting nut and sleeve of shaft do not come in contact with each other (see Fig. 1-4). If they do, move bulkhead connectors accordingly. If mechanism functions incorrectly, repeat procedure or go to Adjustment Checklist.

ADJUSTMENT CHECKLIST

Situation:

Breaker turns ON and OFF, but will not Reset when tripped.

Adjustment:

Loosen the lifting washer/nut while tightening the washer/lockwasher/nut, two or three turns should be sufficient (see Fig. 1-3 or Fig. 1-4).

NOTICE

Check the reset position of the actuator mechanism, that the lifting nut and sleeve of shaft do not come into contact with each other (Fig. 1-4 or Fig. 1-4). If they do, move bulkhead connectors accordingly.

Situation:

Breaker Resets after tripping, but does not turn ON.

Adjustment:

For a K-Flexible Shaft Assembly, loosen the washer/ lockwasher/nut on the end of the shaft while tightening the lifting washer/nut until breaker turns ON with positive action. Tighten both nuts and recheck for ON, OFF, and Reset positions (Fig. 1-3 or Fig. 1-4).

NOTICE

Be certain after adjustment to have a minimum of 1 thread past the washerlockwasher/nut assembly (Fig. 1-3 or Fig. 1-4).

If any other adjustment problems should arise, contact your local Cutler-Hammer representative.

INSTALLATION INSTRUCTIONS FOR DOOR INTERLOCK

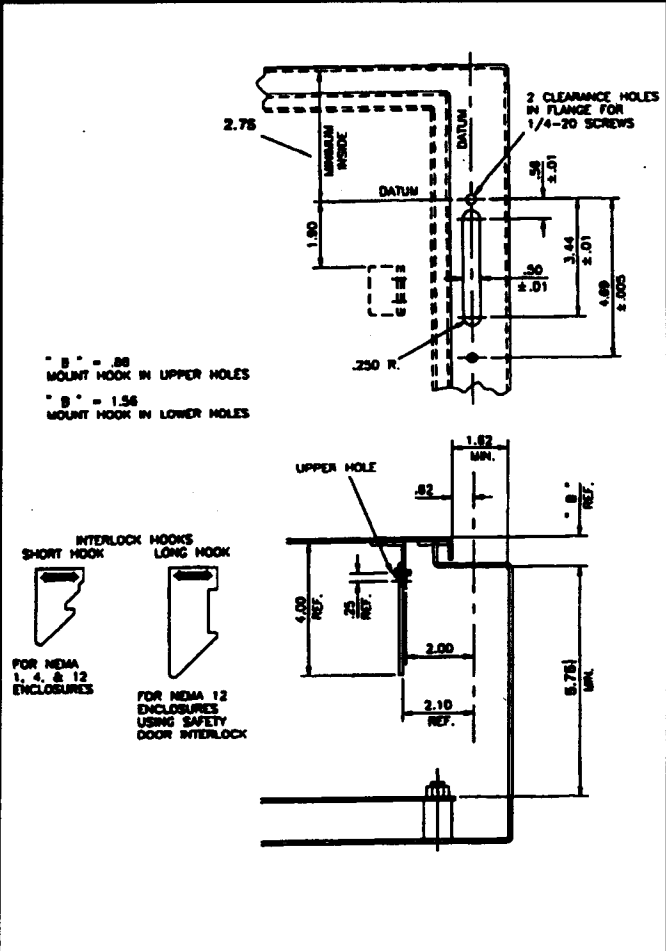

Fig. 1-8 Flange Drilling Plan for Handle and Interlock Blade Mounting Dimensions

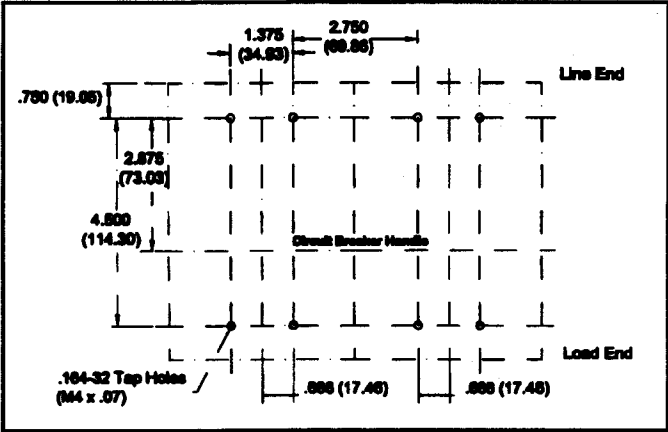

Fig. 1-9 Dual Flex Shaft™ Breaker Drill Plan

Cutler-Hammer
Moon Township, Pennsylvania U.S.A.

Effective 5/99
Style 6608C11H05
Printed in U.S.A.

